

Reverse Path MTC Overview



- **RF Amplifiers and Nodes Tech Tip**
- **Major Entry Points for Ingress**
- **Taps & Passives**
- **Effects of Lost Packets**
- **Real World Findings**
- **Impairments**
- **DOCSIS 2.0 Enhancements and Requirements**
- **SCDMA**



Outside Plant Service and Preventative Maintenance Tech Tip

Background

Amplifiers and nodes located in outdoor environments are subject to extreme temperature changes, humidity, and potentially corrosive conditions.

These effects can cause potential corrosion and metal fatigue over the life of the products.

Mechanical components, gaskets, spring fingers, cables, and connectors are particularly susceptible.

When coupled with excessive use and wear, the combination of these conditions may cause intermittent contact or operation in the amplifier or node.



Maintenance

To ensure that amplifiers and nodes remain stable throughout their expected operational life, technicians and contractors should use proper care when servicing the amplifier and nodes.

Best maintenance practices always include:

- Avoid servicing the housing during high humidity, rain, or snow conditions.
- Always tighten all screws and closure bolts per specifications and in proper sequence using a torque wrench.
- Check the integrity of the RF and weather gaskets on the housing lid and base.
- Use the right tool for the right job.



Service and Preventative Maintenance

At amplifier or node locations with performance issues, periodically take the following steps to further ensure the integrity of the device.

- Remove the chassis cover, unplug any connectors, check, and reseal.
- Re-torque all cover screws and tie down bolts.
- Inspect all spring fingers or shields to ensure they are flexible and making good contact with their mating service.
- Without removing them, loosen hybrid screws and re-torque.
- Visually inspect all surfaces for corrosion or water damage.
- Inspect cables and connectors.
- Periodically apply silicone grease to rubber gaskets.

If corrosion is found or these integrity checks do not alleviate the issue, remove the unit from service.



Troubleshooting

- There are many ways to determine the cause of an RF path problem. It is best to follow a logical sequence from the source to the destination.
- Using the product's block diagram, determine where the signal originates and measure the signal level. Follow the path, continuing to measure wherever a test point or plug-in RF point is accessible.
- Note the RF level at each location and compare to loss or gain per the block diagram. If there are cables flex them vigorously. If the signal level is constant, then the cables are OK. Perform this operation on all paths suspected of having an intermittent performance.
- Any connector is a potential cause of an intermittent response. Check the appearance of connectors, if they are clean and free of corrosion, unplug and re-seat the connectors to clear any possible corrosion buildup.
- Plug-ins are another possible source of intermittent operation. Remove and inspect plug-ins for corrosion. Some third party plug-in attenuators have been found to be intermittent, so check that plug-in attenuators match the expected value.

Major Entry Points for Ingress



- **Studies have shown that 80% of the ingress problems can be attributed to the drop cable running into the house.**
- **Unterminated taps**
- **Loose amplifier housings or corroded connectors**
- **Poor grounding or defective RF shielding**

Headend to Tap Overview



Ingress on the Return Path can enter the network through loose connectors, improperly closed amplifier housings, or cracked cable.

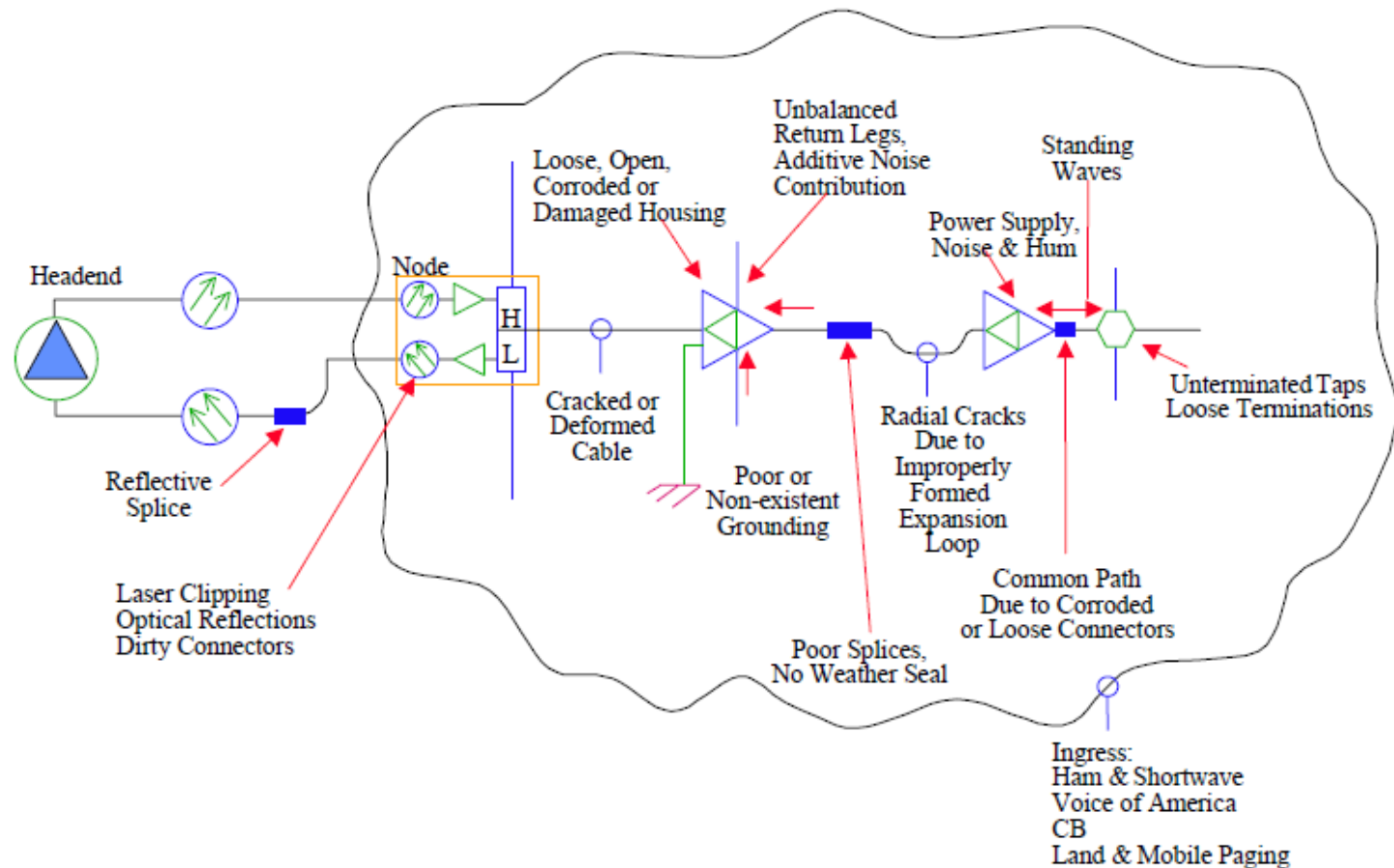

Tap to Customer Premise Overview



The major contribution of ingress is from the tap through the customer premises in-home wiring as shown in Figure 2-2. Faulty customer prepared and installed wiring is an entry point for impulse noise generated by household appliances. Micro-reflections due to improper wiring affect the transmission and reception of digital signals.

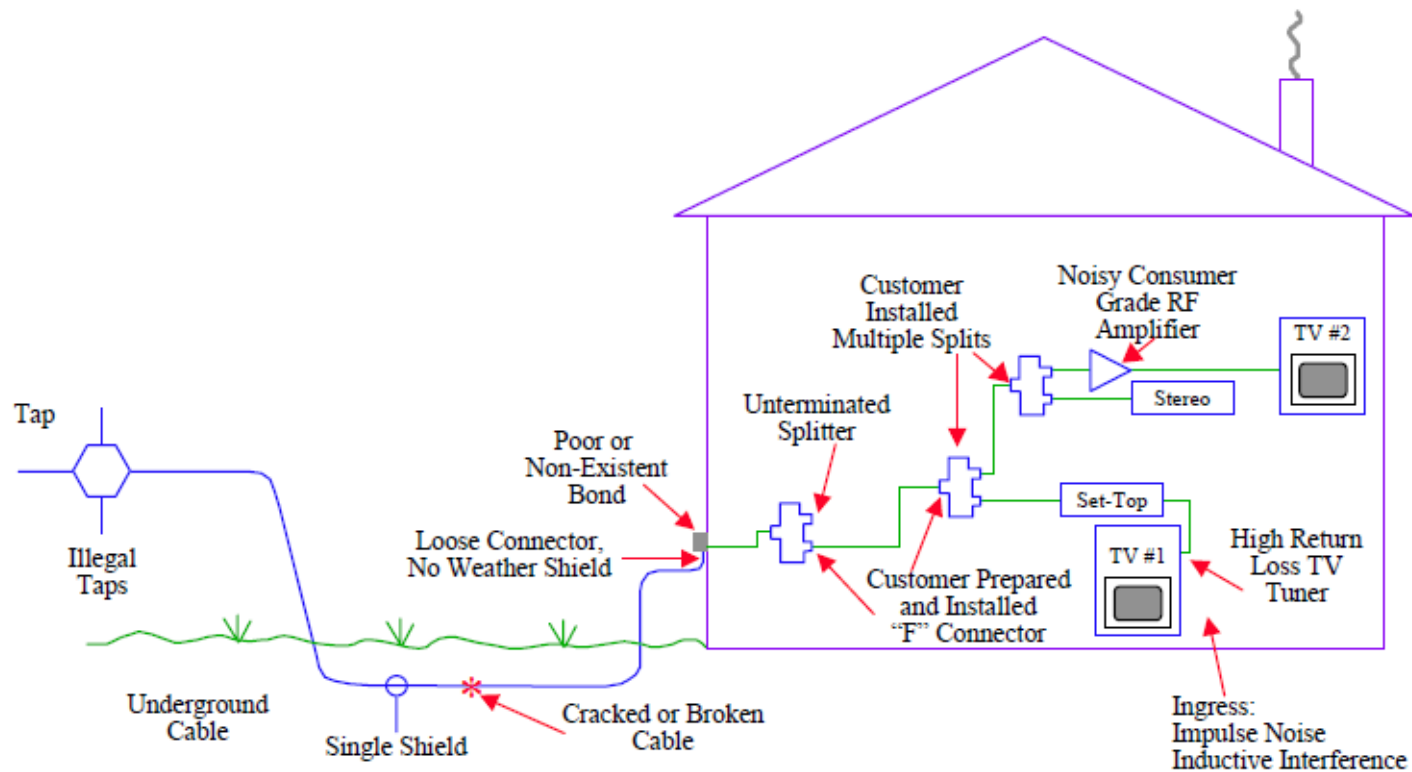

Taps & Passives



Taps:

FFT*-*P (Full Feature Equalizable Tap
standard RF only w/ Signal
Conditioning)

BTT*-*P (Twisted-Pair Power
Extracting w/ Signal Conditioning)

BTTF*-*P (F-port Power Extracting w/
Signal Conditioning)



P-Series Taps



P-Series taps feature:

Auto-seize F-connector for improved reliability

- Increases the clamping force

- Aids in prevention of oxides

F-Port weather sealing

- 100% moisture seal with “epoxy sealed” taps.

Plug-in signal conditioning capability

- T-EQ-* (2 thru 16 dB, 2 dB increments)

- T-CS-* (3 thru 12 dB, 3 dB increments)

- T-RPA/S-* (2 thru 18 dB, 2 dB increments)

- T-HP/S-*

6 kV surge withstand at each port

- All FFT*-*P series taps offer surge resiliency at each F-port.

N-Series vs. P-Series Connector



N-Series F-Connector

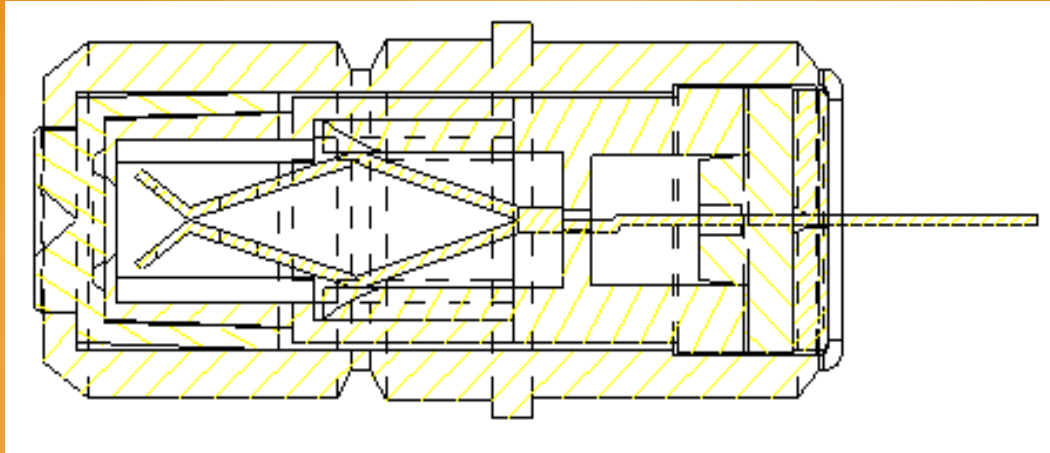

P-Series F-Connector

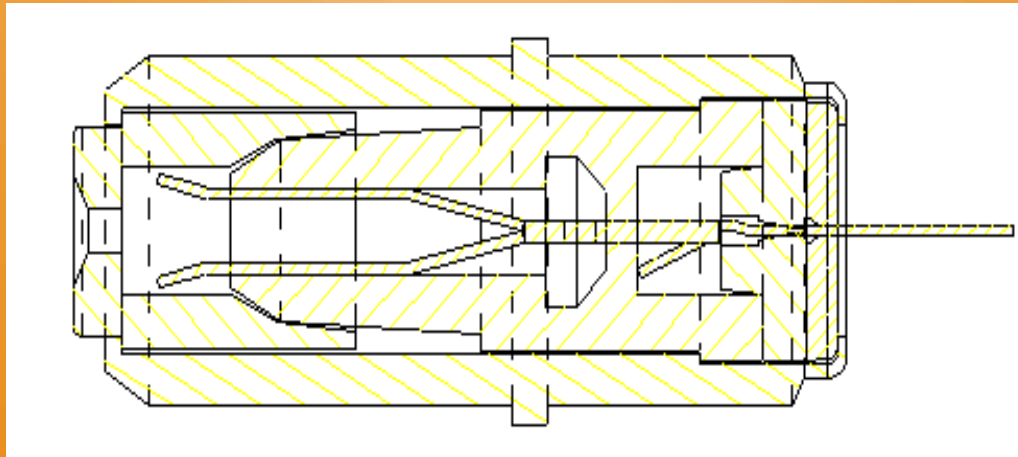

P-Series F-Connector Cross-Section

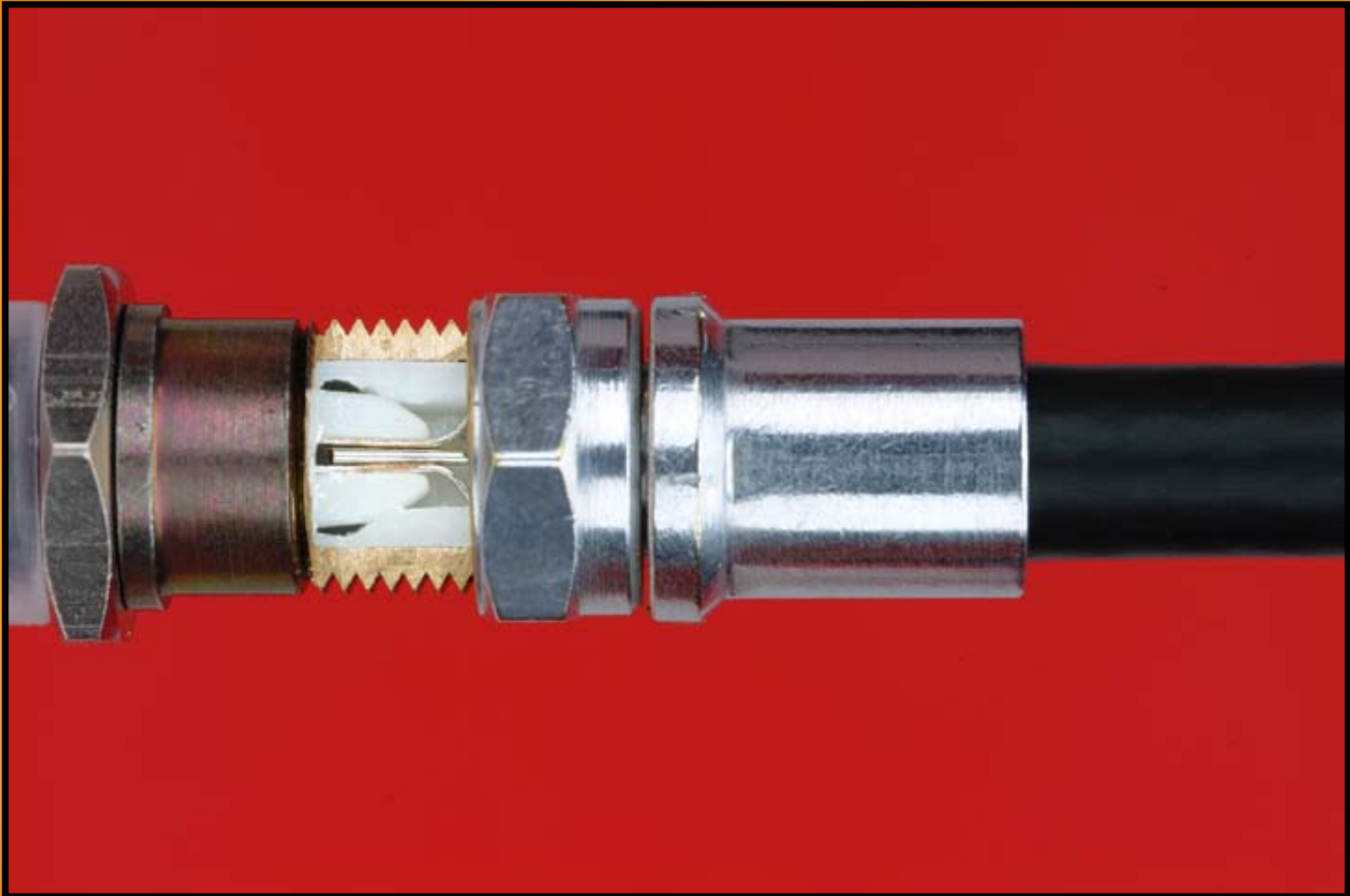

Taps & Passives



CABLE EQUALIZER MODULE

The cable equalizer (T-EQ-*) plug-in module attenuates the return path signal originating from the customer premise in an effort to reduce the effects of system ingress. The cable equalizer also tightens the window of return path signal variation to allow more efficient operation of return transmitters in optical nodes. The module is field configurable via removal of the tap faceplate in order to allow operators to maximize the return path performance.

RETURN PATH ATTENUATOR MODULE

The return path attenuator (T-RPA/S-*) plug-in module provides the same benefits as the cable equalizer module, but accomplishes this via a diplex filter. As a result, the T-RPA/S-* is system split dependent and provides less impact to the forward drop signal than the cable equalizer. The high pass filter (T-HP/S-52) operates in the same manner as the T-RPA/S-* module, but attenuates the return path even greater. This is useful in ingress problem areas where customers are presently not using return path services.



CABLE SIMULATOR MODULE

The cable simulator (T-CS-*) plug-in module for the BTT-P tap provides additional benefits for use in systems containing Motorola's high output level GaAs RF amplifiers and optical nodes. The cable simulator plug-in maintains low loss in the return drop path, while attenuating the forward drop signals to the proper system design levels.

Why Tap Equalization?



Reduce effects of ingress:

Most ingress occurs at drop location

Low value taps allow greatest amounts of ingress

Equalization at tap provides greatest benefit to reduce ingress

Reduce gain variance of signals in return path

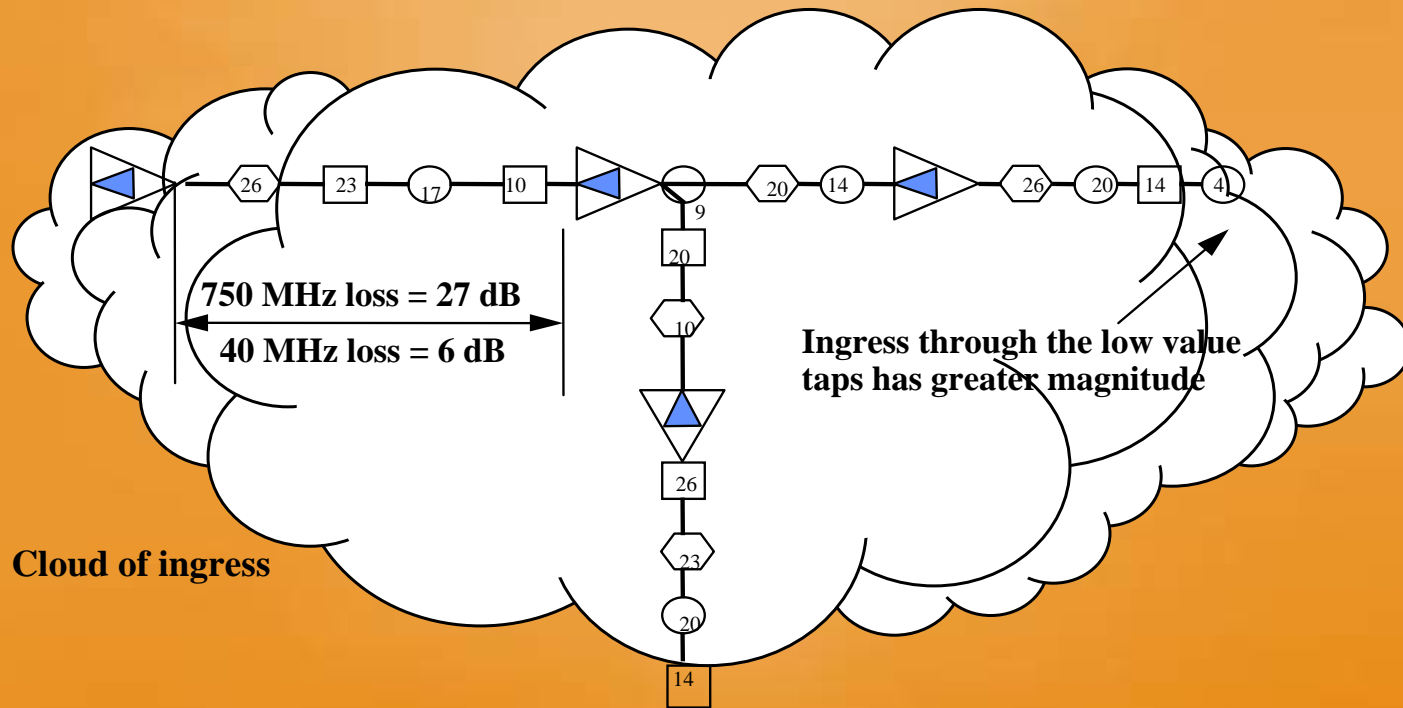

Why Tap Equalization? – cont.



T-EQ-* and T-RPA/S-*:

- Both provide return path conditioning to tighten return path input levels
- Recommended in 17 dB value taps and lower
- T-EQ-* provides nominal loss beyond 108 MHz
- T-RPA/S/* provides flat loss (diplex filter)

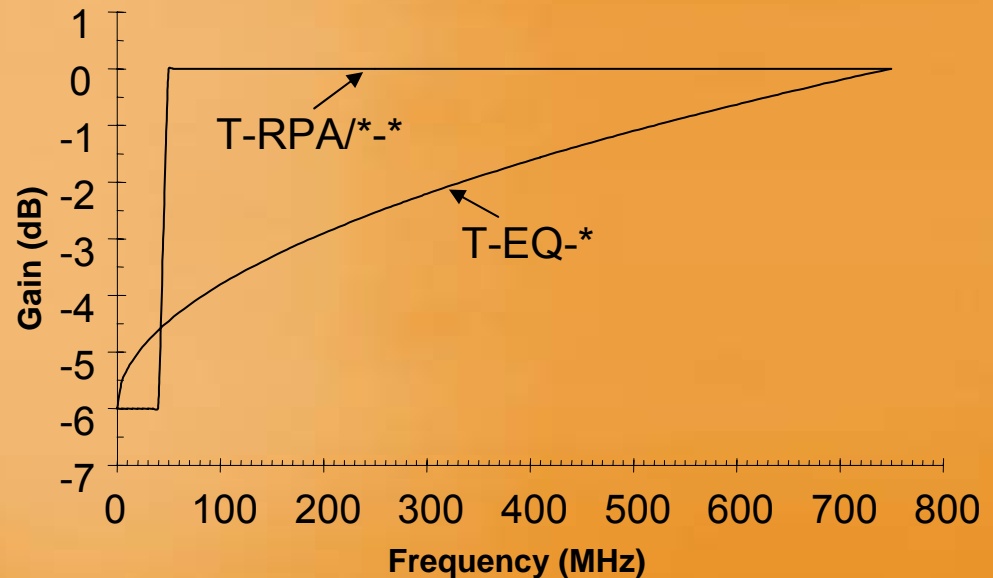

T-CS-*:

- Allows higher output levels to be used without compromising return levels
- Recommended in 23 dB value taps
- Return frequency not affected

Effects of Lost Packets



	Total Packet Lost Rate		
	$\geq 1\%$ $< 3\%$	$\geq 0.1\%$	$\leq 0.01\%$
Voice Quality	Sub Toll Quality	Toll Quality	Toll Quality
Call Completion Rate	$< 98\%$	99.5%	99.95%
FAX	Drop connections and errors on page	Drop connections and error on page	Supported *
Dialup modem	Drop connections	Drop connections	Supported *

* Assuming network timing is lock

Upstream Error Rate



```
CMTS# show controllers cable 12/0 upstream 0
```

```
Cable 12/0/U0 is up
```

```
Frequency 10.000000 MHz, Channel Width 1.600000 MHz, QPSK, Symbol Rate 1.280000
```

```
Mbps
```

```
SNR 36.7 dB
```

```
Nominal Input Power Level 2 dBmV
```

```
part_id=3138, rev_id=2
```

```
Range Payload Size=0xB0
```

```
Request Payload Size=0x18
```

```
Req 108425431, ReqColl 0, ReqNoise 0, ReqNoEnergy 108 # Can be used to indicate congested US
```

```
Rng 25, RngNoise 61
```

```
FECBlks 18249, UnCorFECBlks 0, CorFECBlks 0
```

```
# Could be used to indicate the US  
packet error rate
```

```
Spectrum Group:
```

```
Ranging Backoff: Start = 0, End = 4
```

```
Data Backoff: Start = 2, End = 8
```

```
Initial Ranging Insertion Interval = 200 msec
```

```
Concatenation is enabled
```

```
Minislot Size = 16 ticks, 128 symbols, 64 bytes
```

```
Bandwidth Requests = 12708
```

```
PiggyBack Requests = 122
```

```
Invalid BW Requests = 0
```

```
Minislots Requested = 38812
```

```
Minislots Granted = 38812
```

```
Map Advance (Dynamic) = 200 usecs
```

```
UCD Count 10975
```

Real World Findings



HFC alignment and clean-up is the primary obstacle to successful 64-QAM implementation

Most nodes can support today

Some will work with degraded error rate

Two will likely not carry 64-QAM without clean-up

Low-end impulse noise within the capacity of SCDMA to support channels in 5-15 MHz range

There are relatively strong single microreflections, but within the equalizer's capability to repair

Single reflections are relatively easily handled

Evidence of increasing group delay at the higher return center frequencies on deeper cascades

Wideband channels in this region could be a problem

Real World Findings – cont.



Nodes examined had excessively high noise floors, limiting those nodes to at best 16 QAM

Set top box return is typically 10 dB too high compared to modem level on many nodes.

More of nodes (almost half) have severe impulse

Adequate SNR, but QAM performance will suffer and require TCP retransmits

Common Path distortion evident in several nodes

Energy below 5 MHz is enough to effect laser loading and reduce dynamic range (headroom)



Available SNR - Dynamic Range vs Laser Type

QAM sensitivity to loading varies with laser type

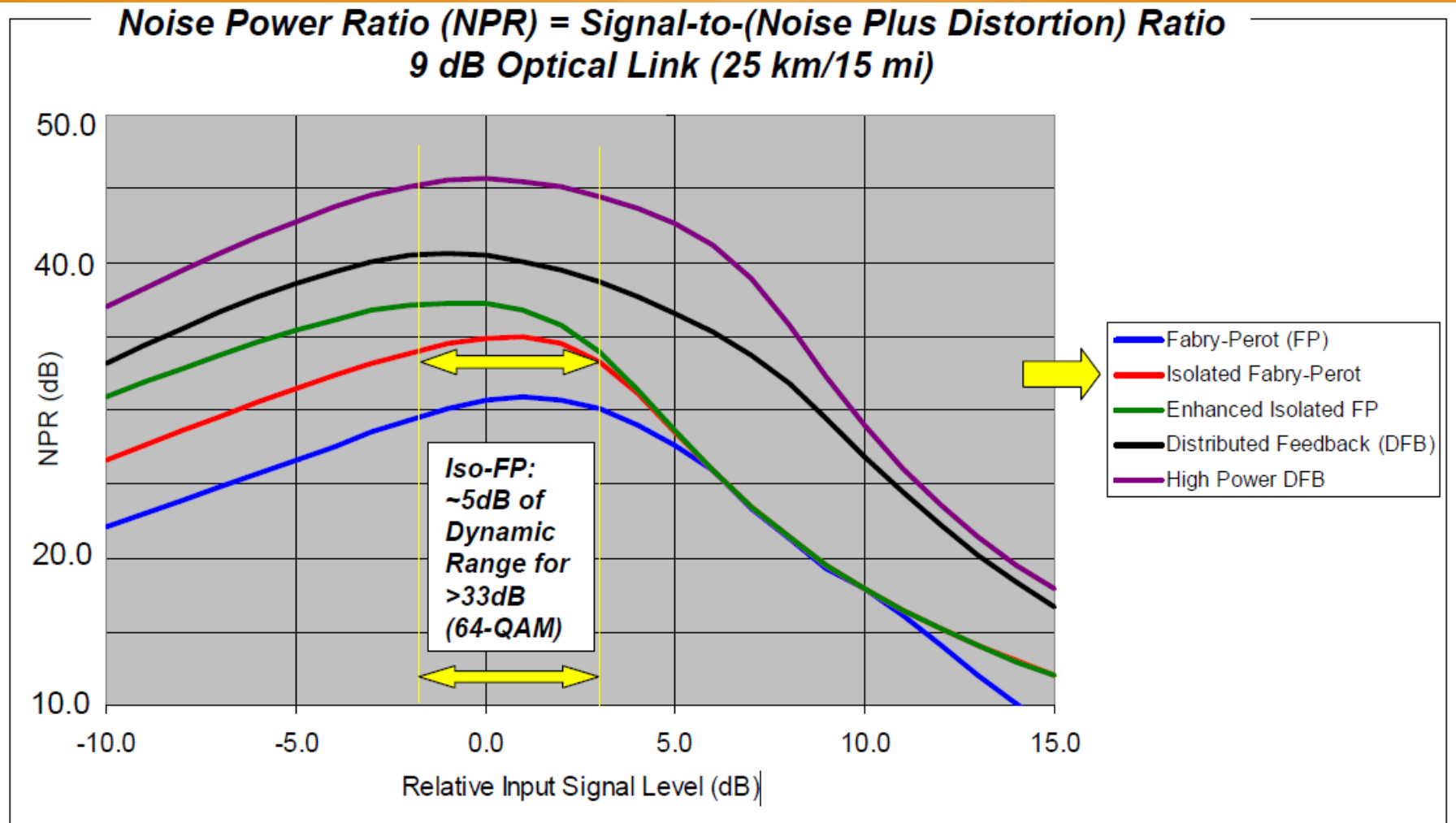

Noise Floors - MER

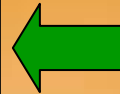
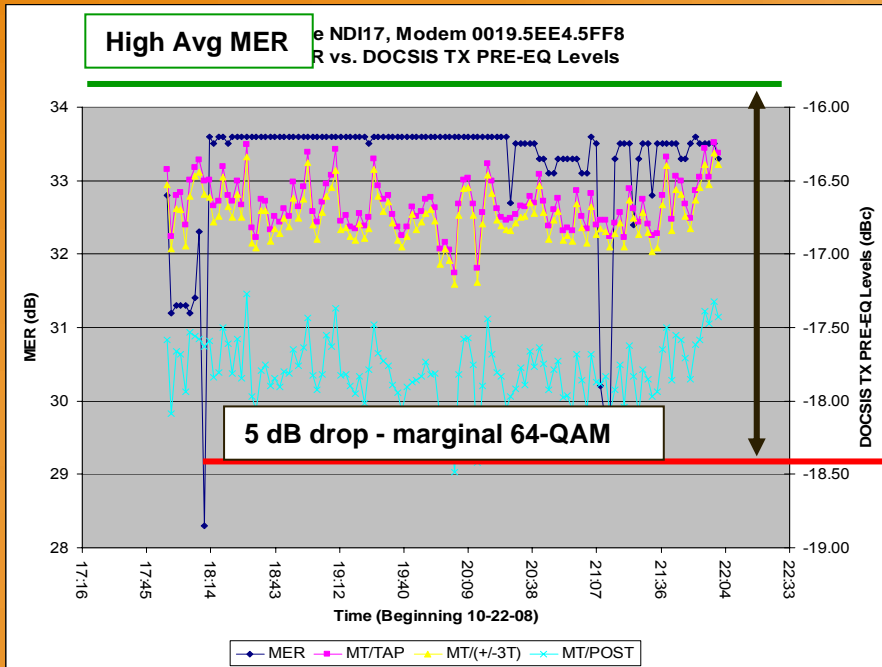

Node NDI17

MER samples taken at 3 minute intervals

>95% high MER, still some brief significant drops

Node NDI03

3 dB MER "drift"

> 5 dB MER spike

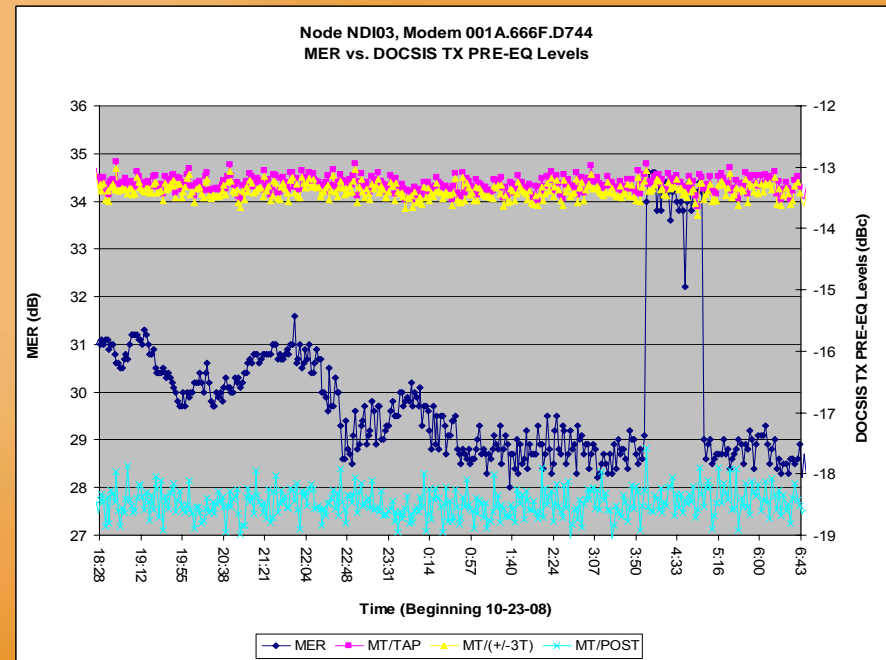

Impulsive Noise

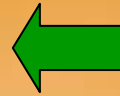
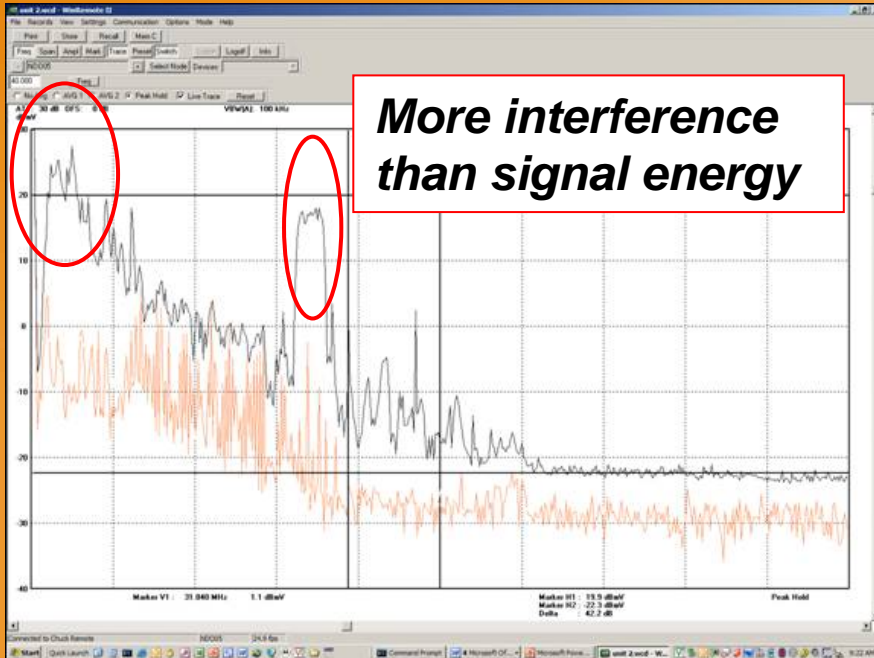

Node ND005

High Impulse with Possible Laser Overload

Node NDQ21

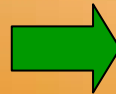

Very High Impulse

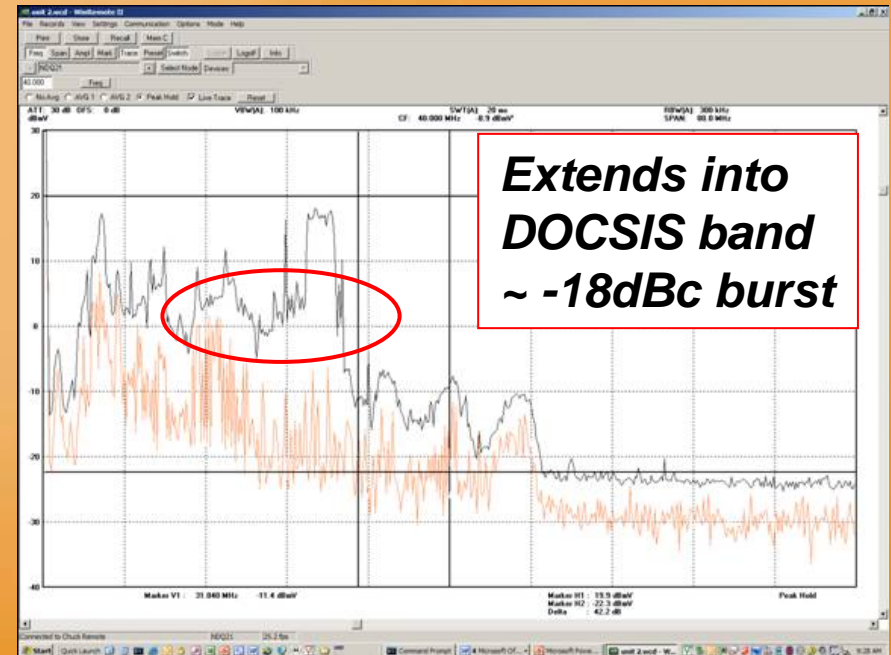

Impulsive Noise



Node NDN02, Modem 0019.5EE6.87FE
MER vs. DOCSIS TX PRE-EQ Levels

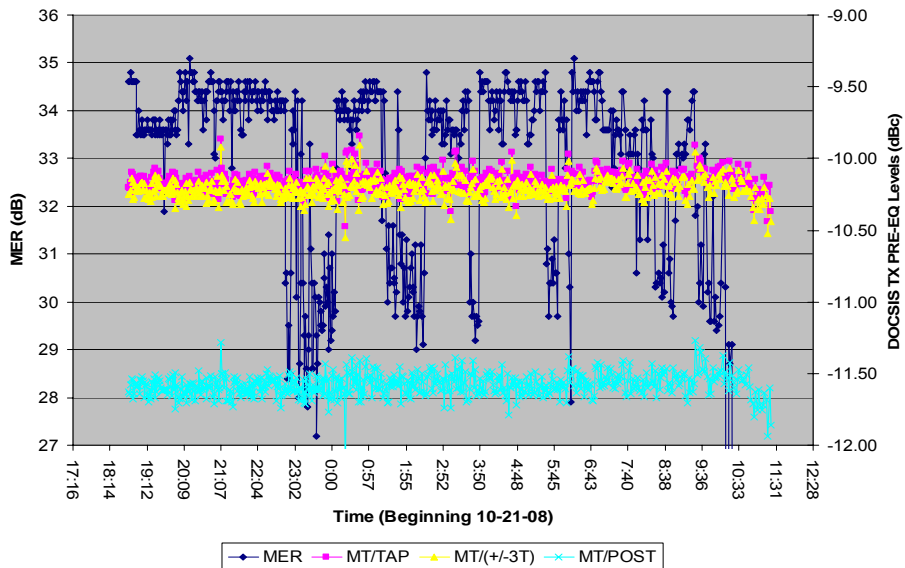

Node NDN02

Wide MER
range of >8 dB
over 18 hrs

MER samples taken
at 3 minute intervals

Node NDI17
HE-located CM
MER range >4 dB
over ~4 hrs

Node NDI17 Headend, Modem 001A.666F.E70E
MER vs. DOCSIS TX PRE-EQ Levels

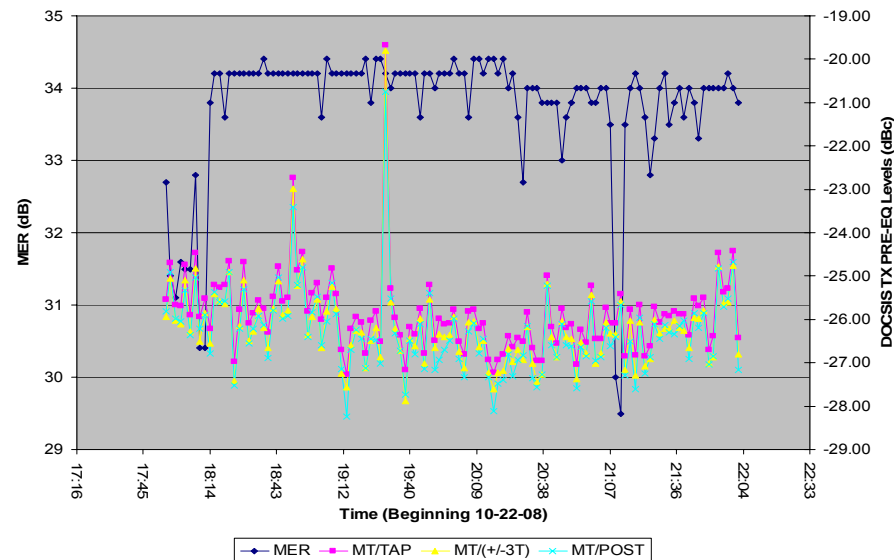

Dynamic Behavior

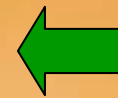
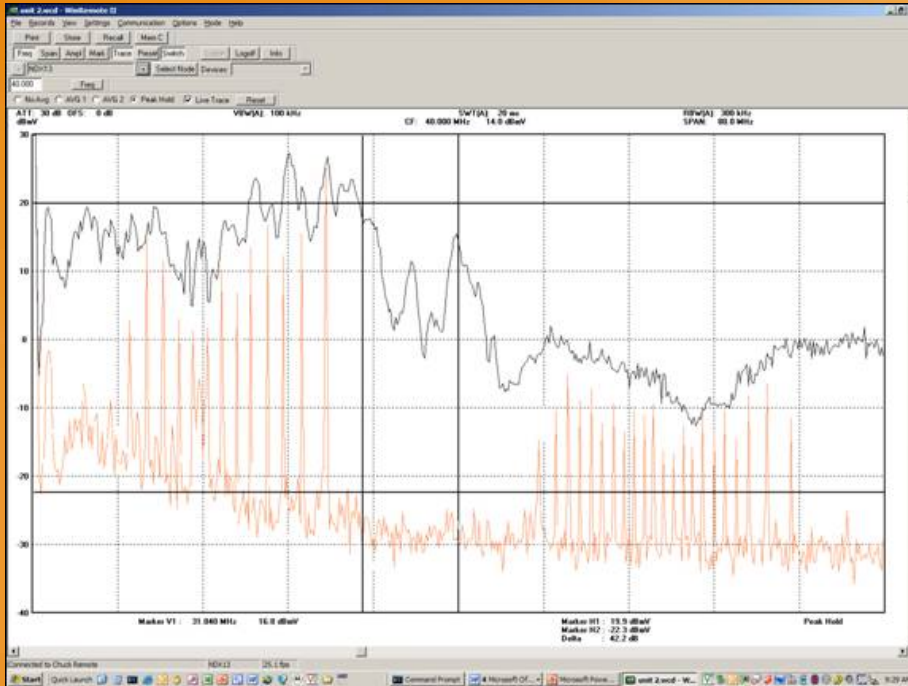

Node NDX13

Catastrophic Impulse
Magnitude



Node NDX13

3 Min Later

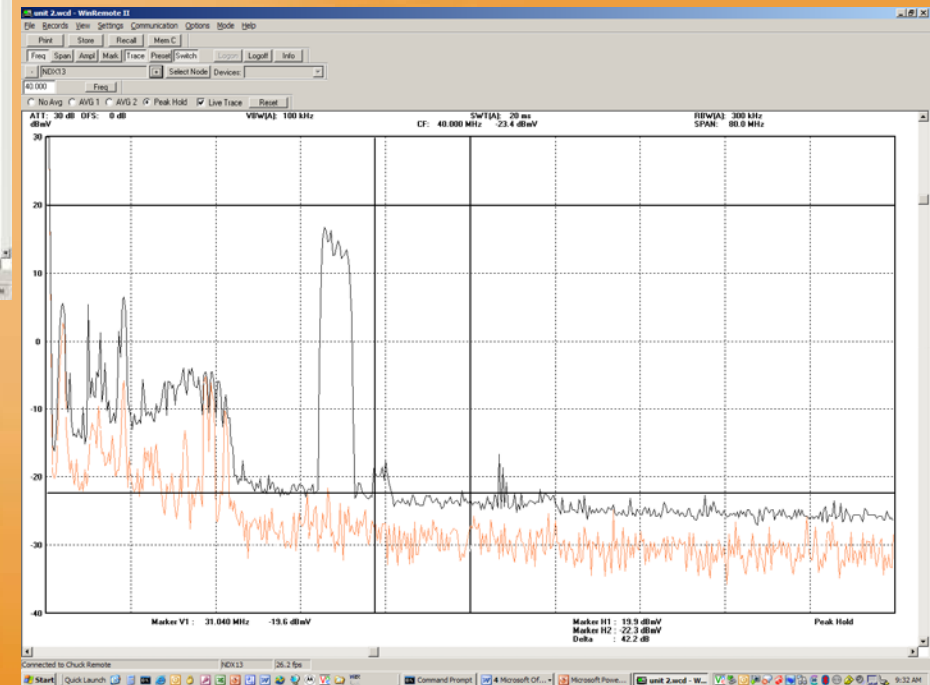

Dynamic Behavior on MER

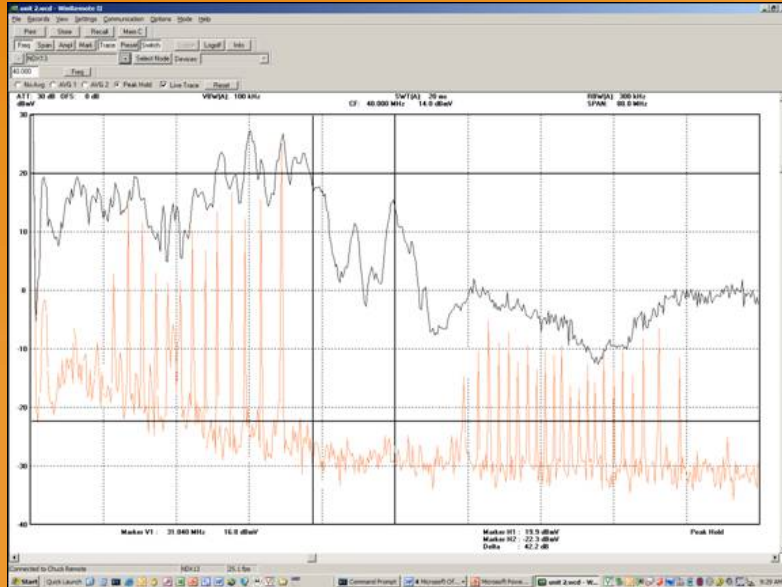

MER Swings >15 dB

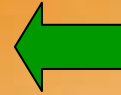

Node NDX13

**Catastrophic Impulse
Magnitude**

**MER samples taken
at 3 minute intervals**

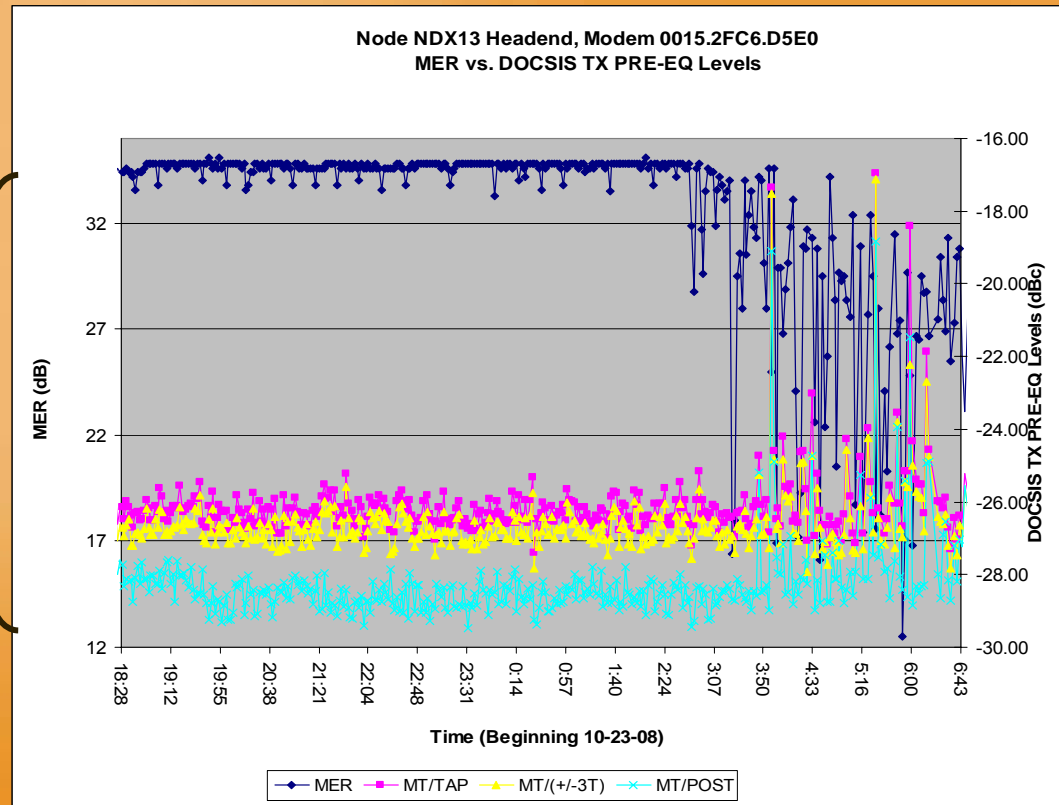

Key Upstream Impairments



- **Ingress and CPD**
 - Narrowband interference from radio signals or common path distortion (CPD)
- **Burst/Impulse Noise**
 - Impulse: Random/periodic spikes in the time domain
 - Burst: 1 us – 100 ms duration
 - Strongest below 20 MHz
 - Can be strong up to 25 MHz
 - Ingress also stronger < 25 MHz
 - Below 25 MHz have both ingress and impulse
- **Relatively Stable Noise Floor**
- **Other impairments**
 - Highly attenuated upstream
 - Long runs/near diplexer edge
 - Micro-reflections
 - Worse for large # actives passed
 - Both affect some modems more
 - Laser dynamic range
 - Non-isolated FP lasers limit full upstream loading with SCDMA

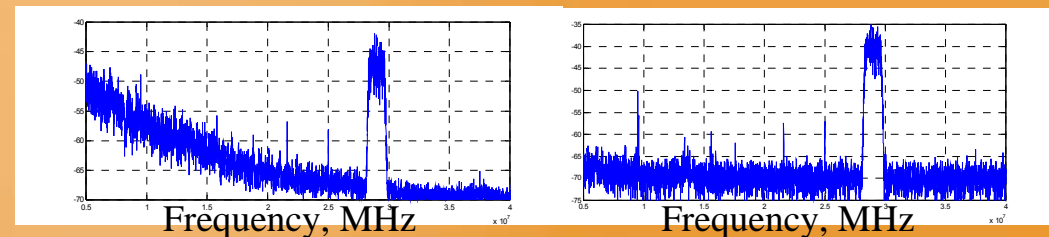
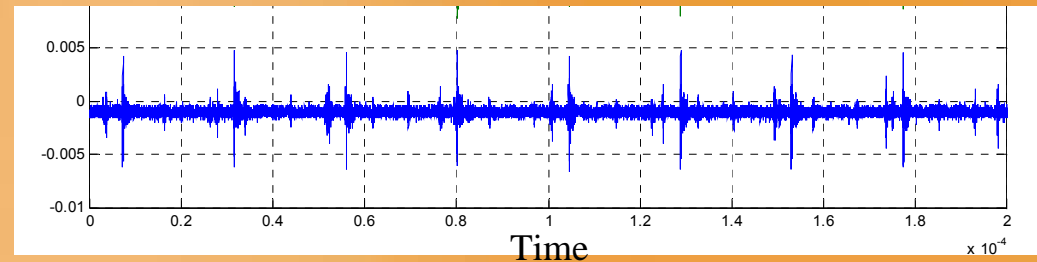
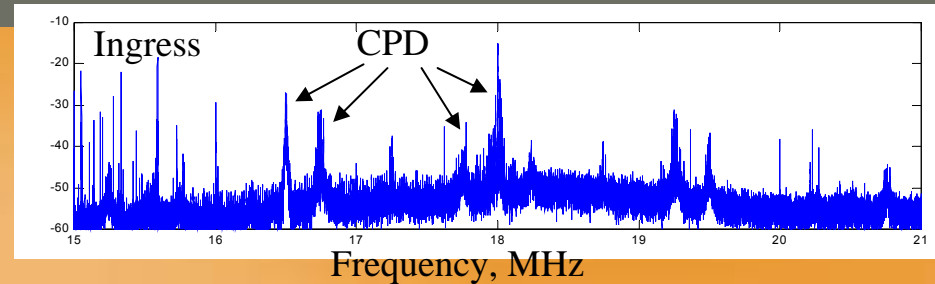

Raised noise floor on spectrum analyzer is due to impulses

Same capture with impulses removed reveals ingress

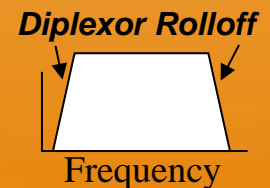

Review of Equalization vs. Linear Impairments

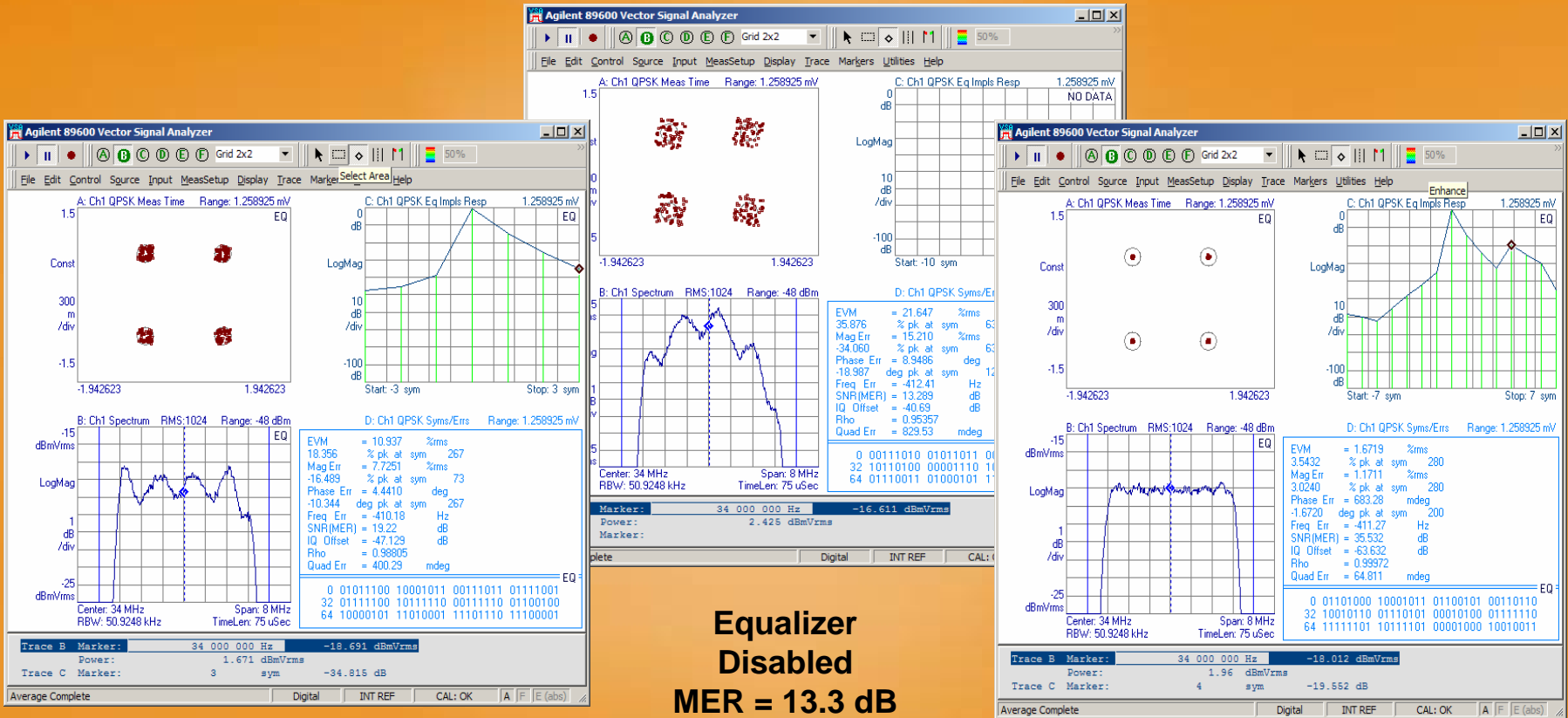

Review of Ingress Noise vs. Ingress Noise Cancellation

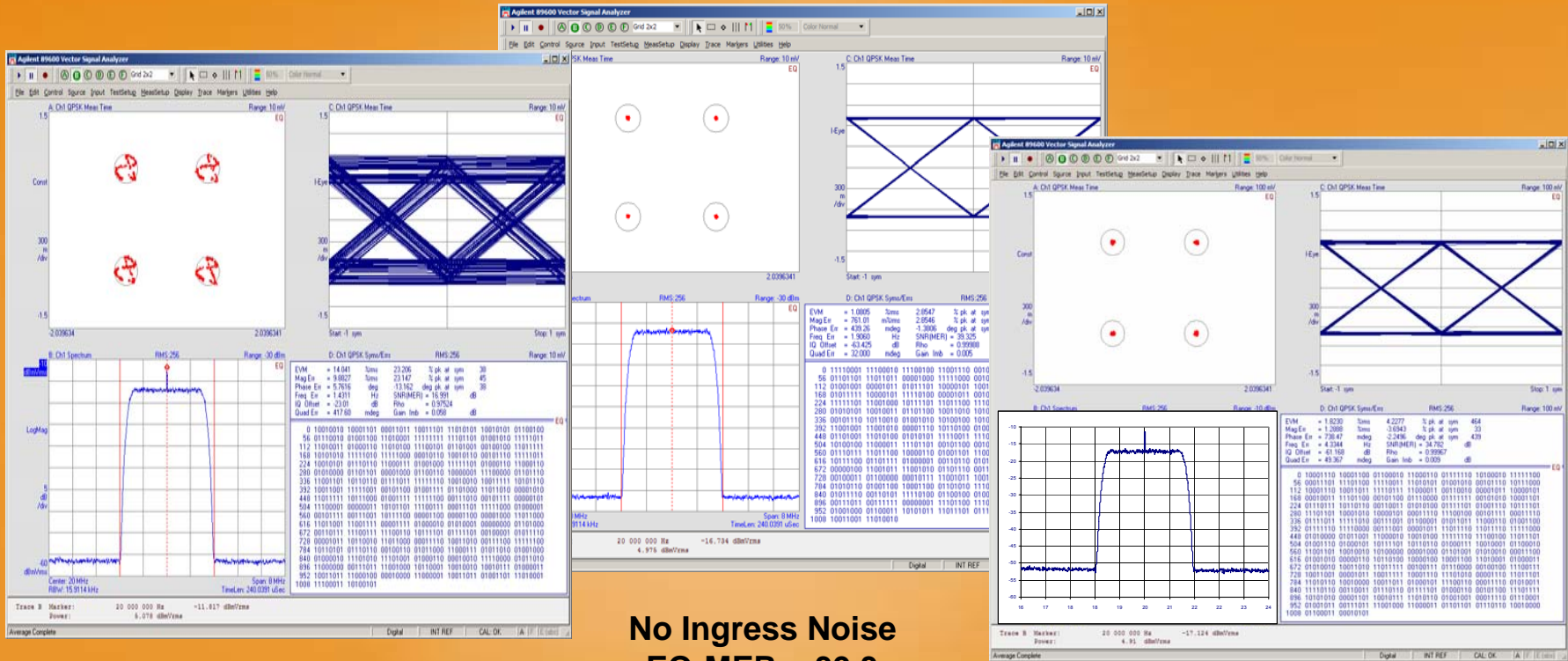

Ingress Noise = -11.8 dBmV
DOCSIS Power = 5.0 dBmV
Ingress Noise Canceller Disabled
EQ-MER = 17.0 dB

Ingress Noise = -11.8 dBmV
DOCSIS Power = 5.0 dBmV
Ingress Noise Canceller Enabled
EQ-MER = 34.7 dB

Review of Amplifier & Cable Modem Non-linear Events



Amplifier Clipped

Note - Spurs Terminate at Diplex Filter Frequency Cut-off

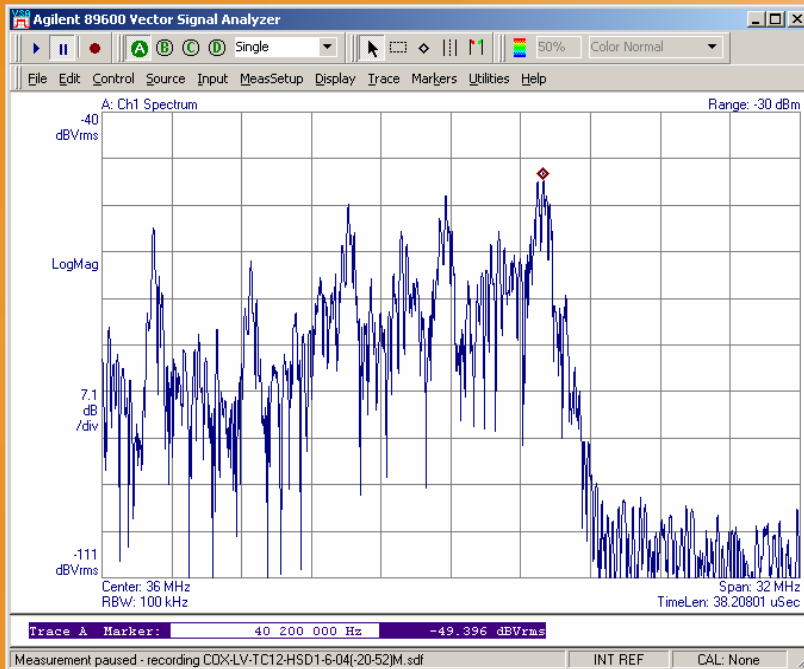

QPSK - EQ-MER < 6 dB

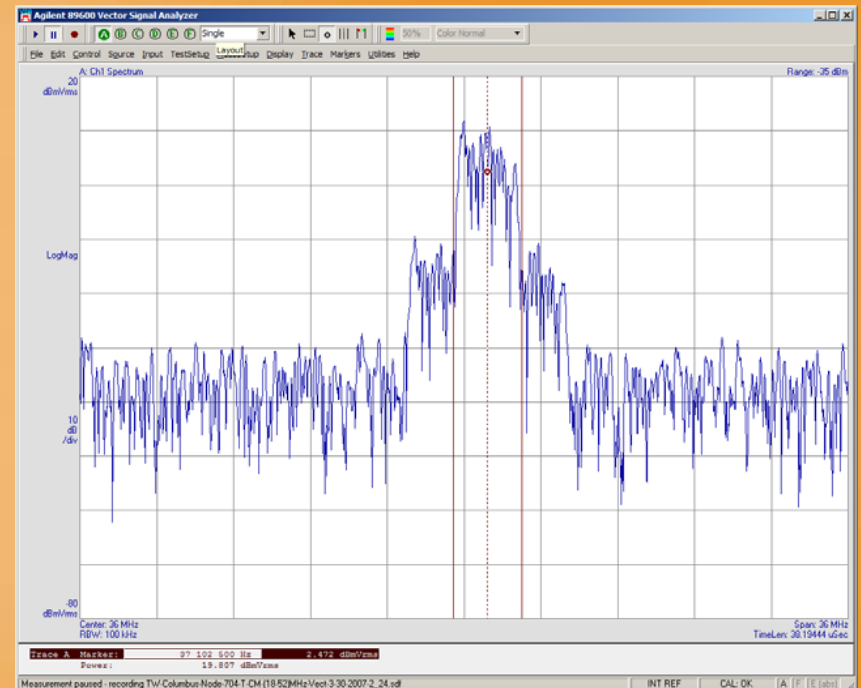

Please note the elevated Noise Floor in both Adjacent Channels, while the remainder of the Return Path exhibits no system non-linearity

Review of DOCSIS Signal in the presence of a System Non-linearity



16-QAM Modulated carrier exhibiting Non-linearity

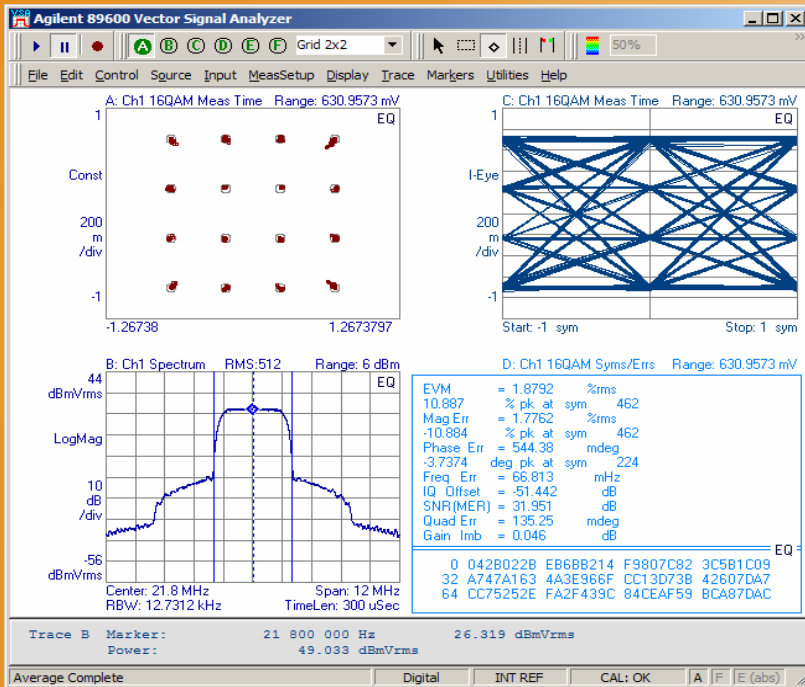

16-QAM – EQ-MER = 31.9 dB

The outer points of the constellation are clearly collapsing inward, but the decision boundary has not been exceeded

256-QAM Modulated Carrier exhibiting Non-linearity

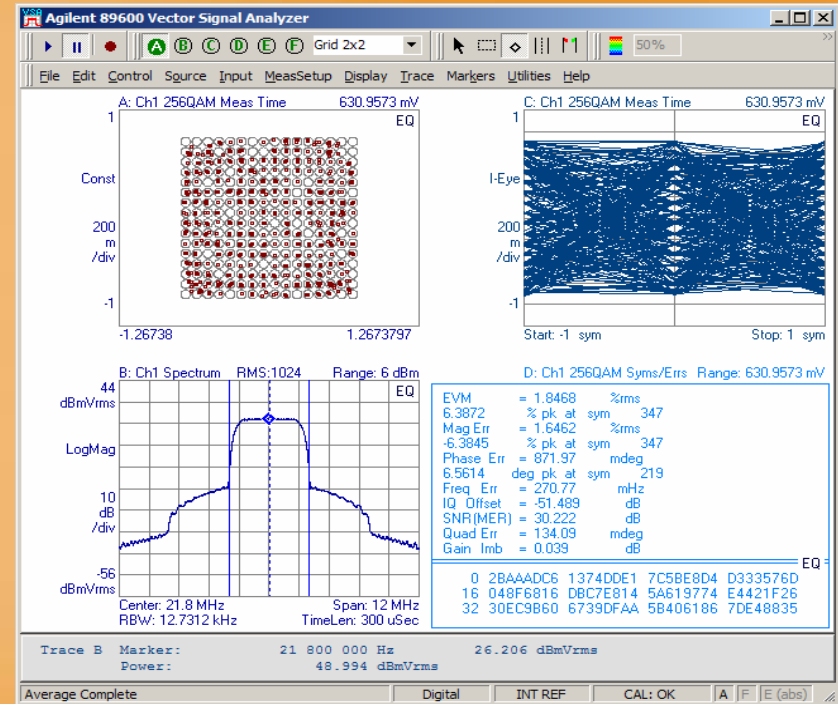

256-QAM – EQ-MER = 30.2 dB

However, the outer points of the constellation have clearly exceeded decision boundary and are in error

Review of Non-linear Impairments



- **Two major types or sources of System Non-linearity present in the return path:**

Common Path Distortion

CATV Industry Understood Non-linearity present on the Common Path (i.e. Coaxial Plant)

Not So Common Path Distortions

Return path optical system non-linearity (i.e. laser and or optical RX system non-linearity)

Return Path Amplifier system non-linearity and is quite rare of an occurrence in recent years

Cable Modem Return Path Transmitter is non-linear

Common Path Distortion



Common path distortion occurs when metal-to-metal contact of a cable to housing, tap or splice mechanism is poor, or it is corroded so that an oxide layer is formed. This oxide layer exhibits a non-linear transfer characteristic. When this corroded contact is near a high level signal, such as after an amplifier, mixing of the downstream signals generate upstream signals in the return path at 6 MHz spacing intervals.

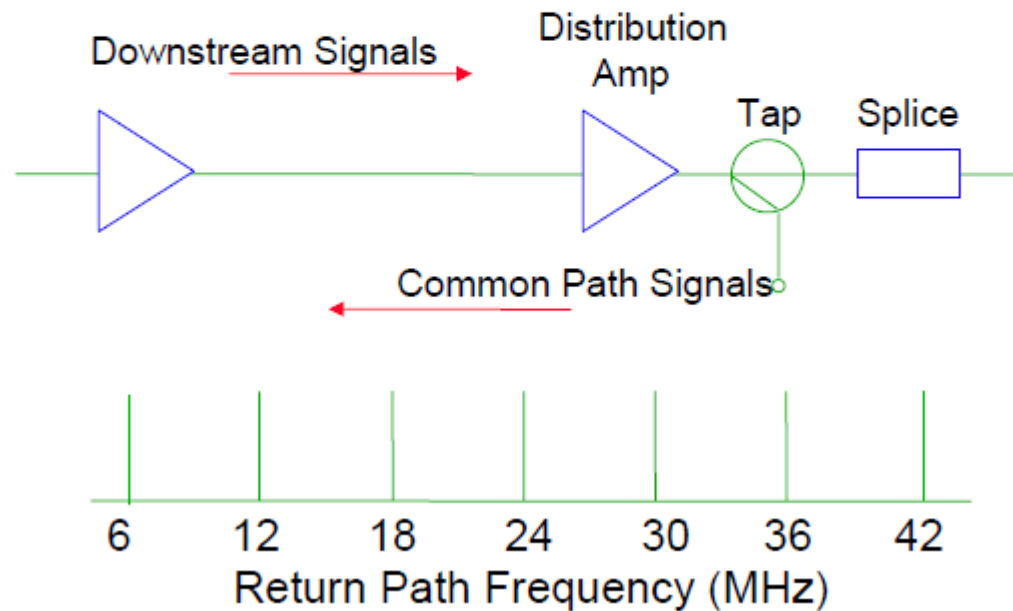

Spectrum Analysis - Forward Path Isolation

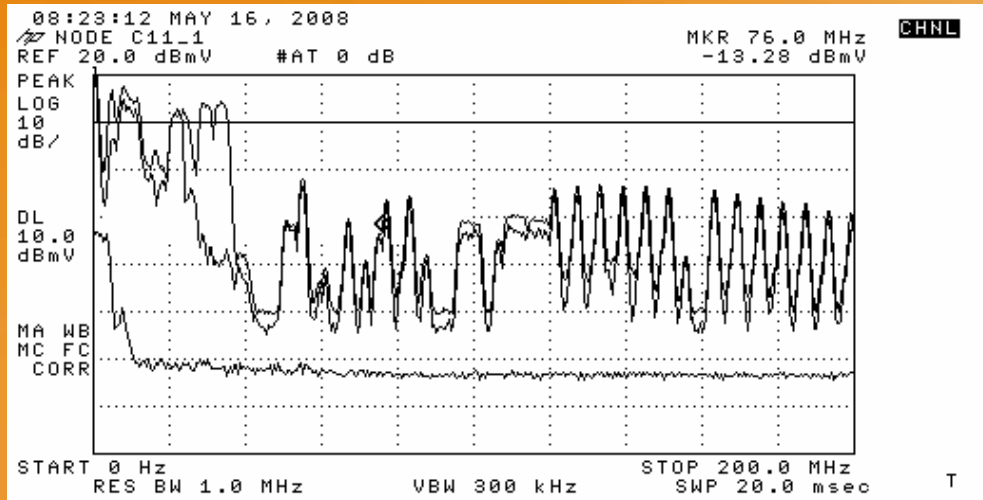

Downstream carriers impinging on return laser and creating overload conditions

Very well-isolated downstream in same plant – possible different node configuration

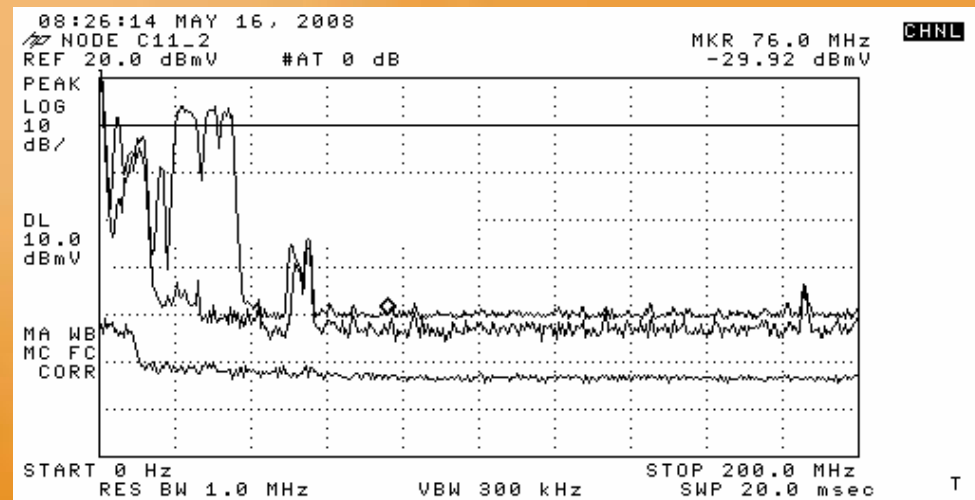

Micro-Reflections



D2.0 Equalization is extremely effective in mitigating the single dominant echo case as described by DOCSIS

D2.0 Equalization is very good at correcting multiple micro-reflections and/or some GDV

Micro-reflection red flags to look for

Deep cascades, prone to group delay (next slide)

6.4 MHz BW channels, in particular with 64-QAM

Aged plants, unknown & mixed equipment

Excessive CPD, impulse (bad connections = poor match)

Clustered MDU environments where poor splits, taps, and low-end amplifiers congregate

Cascade Depth



Deep amplifier cascades = many diplex filters

Each filter sharpens the net frequency response of the cascade

Steepens attenuation roll-off and increases group delay variation

Maximum distortion-free center frequency comes down, more high-end bandwidth unusable

D2.0 Equalization is effective in mitigating GDV

Its effectiveness decreases when combined with micro-reflections

Group Delay red flags to look for are

Adding new upstream channels

Filling the spectrum near the high edge of the band

Supporting cascades $>N+5$

Deploying 64-QAM @ 6.4 MHz (32-QAM in some cases)

Unsure of what their path consists of (lasers and/or diplexers)

Return Path Variables



Several return plant variables impact the ability to move to higher order modulations and higher symbol rates.

- **SNR capability and range of an available SNR - primarily driven by the optical link Laser type**
- **Link length**

- **Return path setup and maintenance practices**
- **Proper return laser power loading and HE levels**
- **Forward path isolation**

- **Ingress and impulse noise degrading the available SNR.**
- **Due primarily to in- home generated disturbances, typically < 20 MHz.**
- **Acts as an added laser power load.**
- **Can be in-band interference to DOCSIS channels**

- **Choice of carrier frequency sensitive to cascade depth for deep cascades**
- **Equalization of frequency response distortions for 64-QAM @ 5.12 Msps**

DOCSIS 2.0 Enhancements



Technology	Primary Benefit
ATDMA & SCDMA	Impulse Noise Immunity (SCDMA)
Increased FEC	Impulse Noise Immunity (ATDMA & SCDMA)
Ingress Canceller †	Narrow-band Ingress Noise (ATDMA)
24-Tap Equalizer	Linear Impairments (Micro-reflections & Duplex Filter Effects)
Additional Modulation-Types (8-QAM, 32-QAM, 64-QAM, 128-TCM)	Increased data rates (Susceptible to Non-linear Impairments)
Logical Channel Operation	Mixed Mode Operation for MTDMA & MSCDMA Removes domination of weakest modem via cable modem grouping

MER & Margin - What's the 64-QAM Effect?



- 64-QAM consumes at least **6-7 dB** of return path margin beyond 16-QAM
- This amount of link margin might not be available
- If it is available, what margin is left requires much more careful attention to obtain and maintain good performance

- Sample of a reasonable scenario. A currently well-functioning, practical return link may deliver a 31 dB MER. That's ~ **17 dB** of margin for QPSK
- That's ~ **10 dB** of margin for 16-QAM
- That's ~ **7 dB** of margin for 32-QAM
- That's ~ **3 dB** of margin for 64-QAM

- 3 dB is a small link margin. Below the level of alignment or cal accuracy that can often be guaranteed
- Below what can protect the link against reasonable dynamic noise and ingress
- Below the types of plant-wide changes that can take place slowly over time and temperature

Link margin this small requires that more attention be paid to details in link setup and to variables within the plant

MER Thresholds and Margin



- CMTS reports channel fidelity as SNR, but it is actually a MER measurement and they are often used interchangeably
- Minimum post-Equalized MER thresholds of **21/24/28 dB** support **16/32/64 QAM**
- Return path setup and maintenance accuracy becomes more critical as MER margin decreases, such as to a few dB
- Smaller dB's of degradation matter and may require attention for 64- QAM, but be invisible to 16-QAM and 32-QAM
- More attention must be paid to laser power loading with multiple digital channels in order to maintain sufficient headroom from overload

Maintenance and Alignment



Upstream alignment & maintenance practices now critically important

- Starts with knowing what is in place and how it was setup
- Simple spectrum monitoring interfered with by new channels
- Eradicating bad links made “good” by increasing the levels

Pre-EQ can hide many sins behind decent link performance

The days of 10 dB of margin to alarms are gone for 64-QAM

- It was nearly impossible to mess up QPSK (<15 dB)
- Transition to 16-QAM was relatively smooth (<22 dB)
- Transition to 64-QAM will not be without attention to details
 - Recommend phased approach 16-32/12.5 Mb-32/25 Mb-64/15 Mb-64/30 Mb

Upstream level accounting is more complicated

- Multiple return channels becoming common
- Range of Max Tx levels across DOCSIS x.x, QAM formats
- Adding SCDMA
- Lack of attention to legacy STB levels

Upgrading to D2.0 Upstream

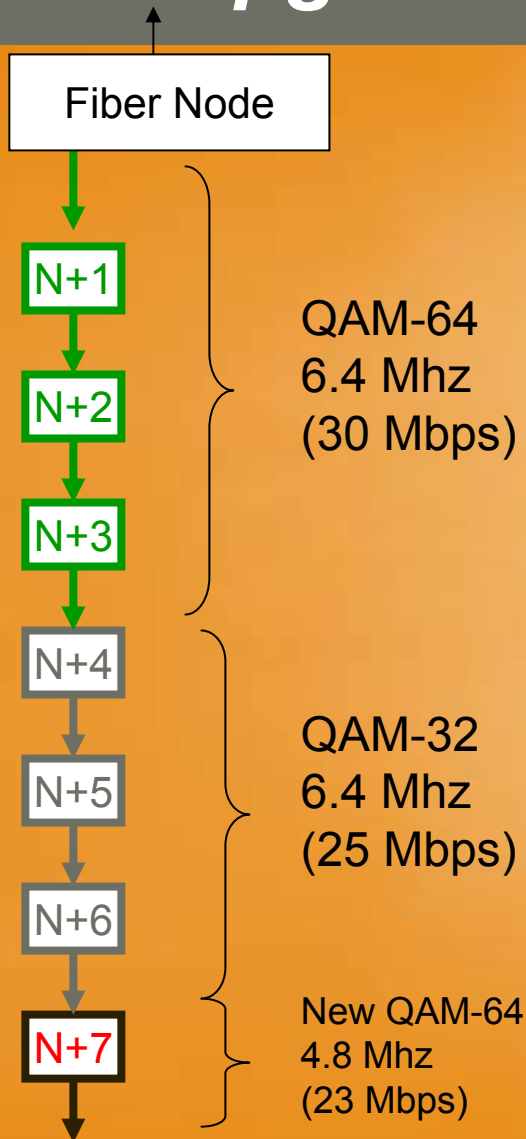

The most economical short-term step for Cable MSOs to increase average upstream bandwidth is upgrading to the higher-width and higher-modulation DOCSIS 2.0 upstream PHY layer options.

Key technical issue with deploying 6.4Mhz /Q64 (30Mbps) is structural microreflections uncorrected by upstream equalization.

Especially for RF amplifier depths above N+5

Almost all fiber nodes can expect a straightforward upgrade to at least 6.4MHz / QAM-32 (25 Mbps)

Fiber nodes with RF amp cascade N+3 or less can expect a straightforward upgrade to 6.4Mhz/ QAM-64 (30 Mbps)

For N+4 to N+6, performance of QAM-64/3.2 Mhz will be marginal

For operation above N+6, Motorola is championing efforts to standardize on a 4.8 MHz channel width with 3.84Msym/sec for QAM-64 (23 Mbps)

Most MSOs also have deployed DOCSIS 1.x CMs, which require at least one 3.2Mhz QAM-16 (10 Mbps) upstream channel per fiber node.



DOCSIS 2.0 Logical Channel Operation

Unique modulation burst profiles applied to “groupings” of modems on a single physical channel

- Removes dependency on weakest modem
- Maximizes throughput or capacity

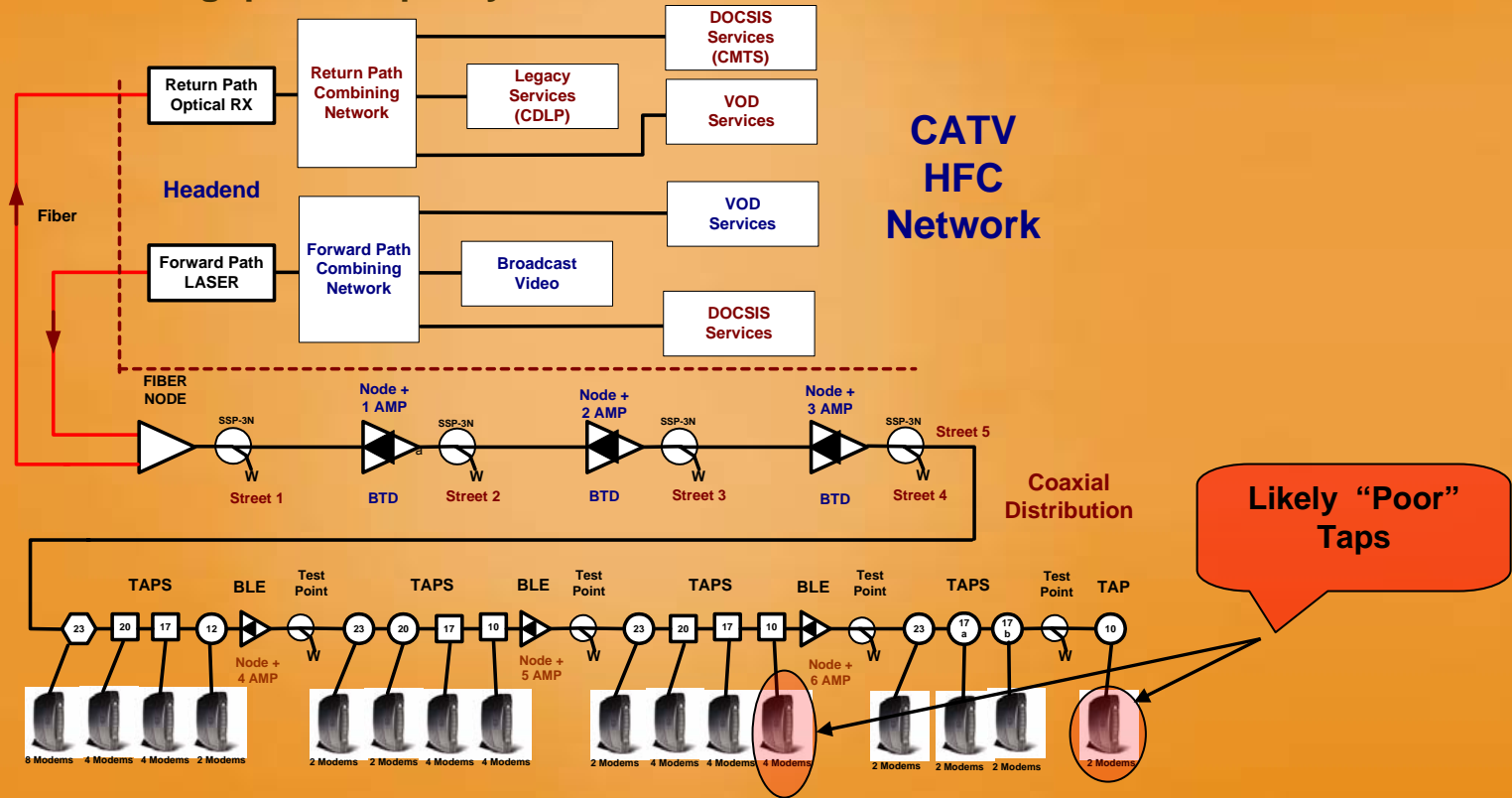

DOCSIS 2.0 Logical Channel Operation – cont.



Predominantly DOCSIS 2.0 CMs in plant

2.0 Logical Channel		
Logical Channel	Modulation	% of Modems
0	QPSK	2 %
1	16-QAM	25%
2	64-QAM	65%
3	256-QAM	8%

Non-Logical Channel		
Logical Channel	Modulation	% of Modems
0	QPSK	100%
	or	
0	16-QAM	98%

LC Total Throughput = 14.28 Mbit/s

NO LC QPSK Throughput = 5.12 Mbit/s
NO LC 16-QAM Throughput = 10.24 Mbit/s

Throughput improves by 9.1 Mbit/s or 180% over 100% Non-LC
or

Throughput still improves by 4 Mbit/s or 39% over 98% Non-LC

The Alternative is to operate in a non-logical channel operation using 16-QAM Modulation and perform maintenance truck-rolls for 2% of modems. While the trucks are out attending to the 2% CMs at least the Throughput is yielding 10.2 Mbit/s.

DOCSIS 2.0 Logical Channel Operation – cont.



Predominantly DOCSIS 1.X CMs in plant

2.0 Logical Channel Operation – DOCSIS 1.X		
Logical Channel	Modulation	% of Modems
0	QPSK – FEC - T= 10	2%
1	QPSK – FEC – T = 2	18%
2	16-QAM FEC – T= 10	60%
3	16-QAM FEC – T= 4	20%

Non-Logical Channel – DOCSIS 1.X		
Logical Channel	Modulation	% of Modems
0	QPSK – FEC - T= 10	100%
	or	
0	QPSK – FEC - T= 2	98%

LC Total Throughput = 7.21 Mbit/s

NO LC 100% QPSK Throughput = 4.05 Mbit/s
NO LC 98% QPSK Throughput = 4.27 Mbit/s

Throughput improves by 3.17 Mbit/s or 78% over 100% Non-LC
 or

Throughput still improves by 2.94 Mbit/s or 69% over 98% Non-LC

The Alternative is to operate in a non-logical channel operation using QPSK Modulation and perform maintenance truck-rolls for 2% of modems. While the trucks are out attending to the 2% CMs at least the Throughput is yielding 4.27 Mbit/s.

Using Logical Channel Operation as an Adaptive Bandwidth Operation



Key Considerations for Adaptive Bandwidth Operation:

- **EQ-MER – Accuracy of EQ-MER Estimation:**
 - Measurement Accuracy versus TIME of DAY
 - Measurement Accuracy versus Ingress Noise & Signal Power
 - Accuracy of 64-QAM vs. 32-QAM vs. 16-QAM estimations
 - Hysteresis Considerations to prevent toggling back and forth on Various Modulation Profiles
- **Wideband FFT “Fast Fourier transform” – Spectral Analysis Accuracy**
 - Accuracy of Return Path Laser Dynamic Range Estimation
 - How often is a Wideband FFT Measurement required during Peak Traffic Period to accurately predict the optimum Throughput (Bandwidth)
- **Narrowband FFT – DOCSIS Bandwidth Spectral Analysis Accuracy**
 - Accuracy of Ingress Noise Cancellation Prediction versus Modulation Type
 - How much Ingress Noise Bandwidth variation exists and can it accurately be predicted versus Modulation Type.

Using Logical Channel Operation as an Adaptive Bandwidth Operation



Key Considerations for Cable Operators:

- **Is a Dynamic Bandwidth Scheme a Technique that the MSO would take advantage of?**
 - Is having a technique that always provides the MSO with the Optimum Throughput, though be it variable, a technique that the MSO is willing to capitalize on?
 - Are there Limits to an Acceptable Percentage of Throughput (Bandwidth) Variation?
 - How would an MSO deal with Capacity Planning?
- **How Often over a 24 Hour period, would the MSO be willing to accept a Variation Bandwidth?**
 - Is every 15 minutes excessive?
 - Is once a day sufficient?
 - Is once an hour an acceptable rate of change?

Advanced Spectrum Management



- **Advanced Spectrum Management offered by the DOCSIS 2.0 CMTS is the only reliable way for the MSO to obtain invaluable DOCSIS Performance Impacting information on a 24/7 Basis.**
- **In order to be most effective for the MSO, it is obvious that the Entire Return Path Spectrum be analyzed both via FFT Measurements & Coherent EQ-MER Measurements.**
- **Due to Return Path Laser System Non-linearity, it is critical that the EQ-MER Estimation be performed using a Data Grant Modulation Type. Simply stated, one needs to perform an EQ-MER Estimation on a 64-QAM Constellation in order to accurately predict 64-QAM Performance Margin.**

Spectral Planning



- Adding channels may involve use of spectrum that is typically less robust.
- Noisy spectrum begins below ~15-18 MHz
- Use SC-DMA to recover the most troublesome spectrum in this region.
- Live plant testing demonstrates superiority in high noise/high impulse environments over AT-DMA

- Constraints on choice of higher frequencies or on the modulation profiles used.
- Limited available spectrum at end of band may preclude widest (6.4 MHz) channel
- Performance sensitivity to carrier frequency at high end of 42 MHz band for 64-QAM
- For N+7 cascades or greater, recommend center frequency ≤ 35 MHz for 5.12 Msps, center frequency ≤ 38 MHz for 2.56 Msps

SCDMA



SCDMA allows use of upstream spectrum edges (below 20 MHz, near upper band edge) when TDMA would fail

Combined ingress and impulse immunity

Impulse noise robustness for <15 MHz better than ATDMA

Need both TDMA and SCDMA to maximize upstream capacity

ATDMA Better with poor lasers, D2.0, and mix of field modems

SCMDA has high pk-avg but fully loading return has same effect

New D3.0 SCDMA features are important

Maximum Schedule Codes (MSC) - SNR boost on lossy channels

Active Code Selection – Big part of improved ingress cancellation

Code Hopping – Distributes any frequency-dependent pain equally